

# TECHNICAL DRAWING

## YXJ-10017

50CL—580gr / Extra Flint Material

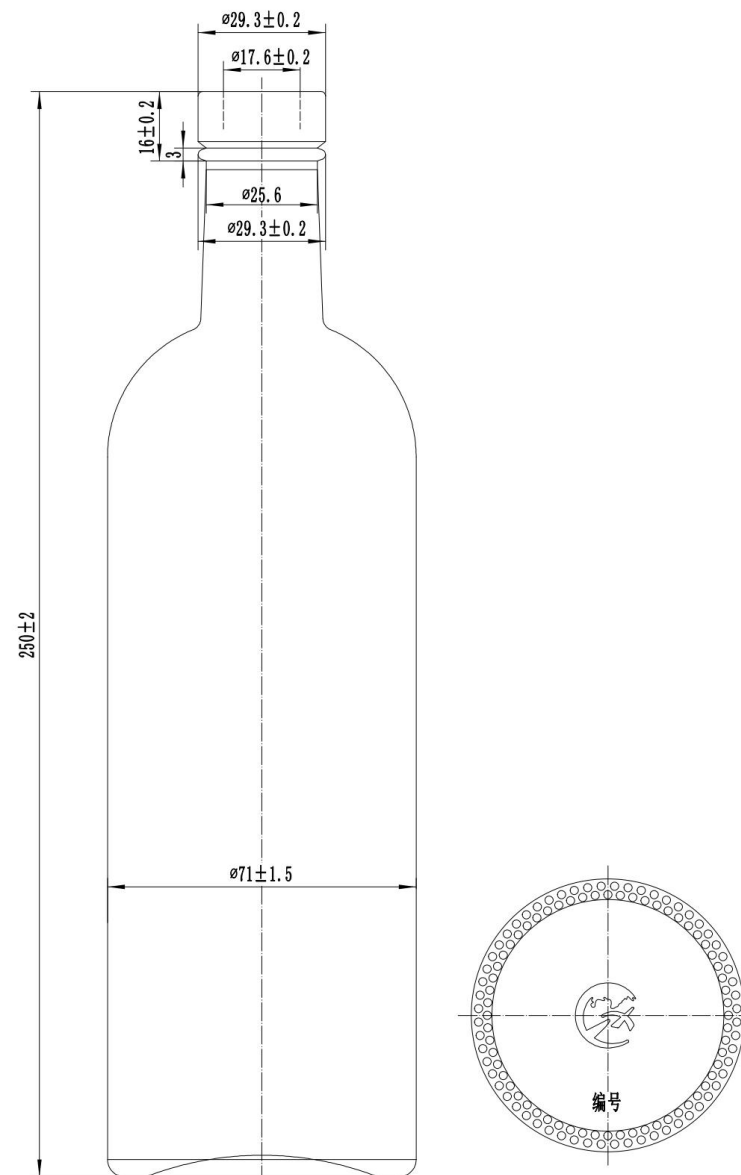

**BRIVERGLASS**

NAME OF BOTTLE :	YXJ-10017 50CL		
CAPACITY :	500ml	GLASS WEIGHT :	580±10g
FULL CAPACITY :	530±10ml	GLASS HEIGHT :	250±2mm
DIAMETER :	71±1.5mm	MATERIAL :	EXTRA FLINT
FINISH OUTSIDE :	29.3±0.2mm	FINISH INSIDE :	17.6±0.2mm

Please carefully review the technical drawings. Bottles that comply with the technical drawings are considered qualified products.

Info@briverglass.com | www.briverglass.com