

TECHNICAL DRAWING

YXJ-10302

75CL—650gr / Extra Flint Material

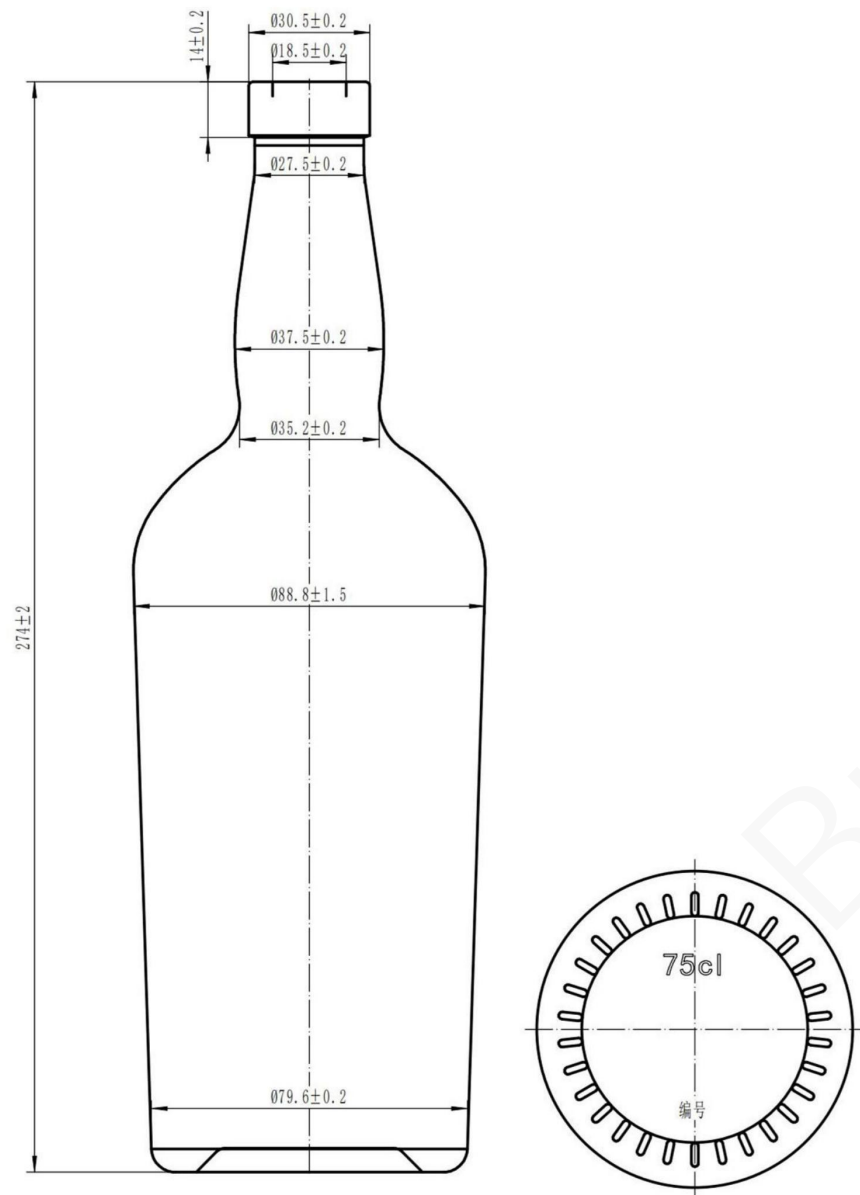

BRIVERGLASS

NAME OF BOTTLE :		YXJ-10302 75CL	
CAPACITY :	750ml	GLASS WEIGHT :	650±10g
FULL CAPACITY :	777ml	GLASS HEIGHT :	274±2mm
DIAMETER :	88.5±1.5mm	MATERIAL :	EXTRA FLINT
FINISH OUTSIDE :	30.5±0.2mm	FINISH INSIDE :	18.5±0.2mm

Please carefully review the technical drawings. Bottles that comply with the technical drawings are considered qualified products.

Info@briverglass.com | www.briverglass.com